

New Sharon

Map Lot 14-47-01

Account 1307

Location Beans Corner Road

Card 1 Of 1 10/16/2024

Building Style 6 Split Level	SF Bsmt Living 0	Layout 1 Typical
1.Conv. 5.Garrison 9.Other	Fin Bsmt Grade 0 0	1.Typical 4. 7.
2.Ranch 6.Split 10.Gar/Apt	Secondary Heat 0	2.Inadeq 5. 8.
3.R Ranch 7.Contemp 11.Cottage	Heat Type 100% 8 Floor/Wall Unit	3.Poor 6. 9.
4.Cape 8.Log 12.Dblewid	1.HWBB 5.FWA 9.No Heat	Attic 9 None
Dwelling Units 1	2.HWCI 6.GravWA 10.Radiant	1.1/4 Fin 4.Full Fin 7.
Other Units 0	3.H Pump 7.Electric 11.	2.1/2 Fin 5.FI/Stair 8.
Stories 1 One Story	4.Steam 8.FI/Wall 12.	3.3/4 Fin 6. 9.None
1.1 4.1.5 7.	Cool Type 0% 9 None	Insulation 1 Full
2.2 5.1.75 8.	1.Refrig 4.W&C Air 7.	1.Full 4.Minimal 7.
3.3 6.2.5 9.	2.Evapor 5. 8.	2.Heavy 5. 8.
Exterior Walls 1 Wood Siding	3.H Pump 6. 9.None	3.Capped 6. 9.None
1.Wood 5.Stucco 9.Other	Kitchen Style 2 Typical	Unfinished % 0%
2.Vin/Al 6.Brick 10.Cement	1.Modern 4.Obsolete 7.	Grade & Factor 3 Average 100%
3.Compos. 7.Stone 11.	2.Typical 5. 8.	1.E Grade 4.B Grade 7.
4.Asbestos 8.Concrete 12.	3.Old Type 6. 9.None	2.D Grade 5.A Grade 8.SC Grade
Roof Surface 3 Sheet Metal	Bath(s) Style 2 Typical Bath(s)	3.C Grade 6.AA Grade 9.Same
1.Asphalt 4.Composit 7.SS	1.Modern 4.Obsolete 7.	SQFT (Footprint) 456
2.Slate 5.Wood 8.	2.Typical 5. 8.	Condition 2 Fair
3.Metal 6.Roll Roo 9.	3.Old Type 6. 9.None	1.Poor 4.Avg 7.V G
SF Masonry Trim 0	# Rooms 6	2.Fair 5.Avg+ 8.Exc
Solar Voltaic 0	# Bedrooms 3	3.Avg- 6.Good 9.Same
OPEN-4-CUSTOM 0	# Full Baths 1	Phys. % Good 0%
Year Built 1980	# Half Baths 1	Funct. % Good 100%
Year Remodeled 0	# Addn Fixtures 0	Functional Code 9 None
Foundation 1 Concrete	# Fireplaces 0	1.Incomp 4.Delap 7.No Power
1.Concrete 4.Wood 7.		2.O-Built 5.Bsmt 8.No Power
2.C Block 5.Slab 8.		3.Damage 6.Common 9.No Power
3.Br/Stone 6.Piers 9.		Econ. % Good 100%
Basement 0		Economic Code None
1.1/4 Bmt 4.Full Bmt 7.		0.None 3.No Power 7.
2.1/2 Bmt 5.None 8.		1.Location 4.General 8.
3.3/4 Bmt 6. 9.None		2.Encroach 9.None 9.
Bsmt Gar # Cars 0		Entrance Code 5 Estimate
Wet Basement 0		1.Interior 4.Vacant 7.
1.Dry 4. 7.		2.Exterior 5.Estimate 8.
2.Damp 5. 8.		3.Informal 6.Reviewed 9.
3.Wet 6. 9.		Information Code 5 Estimate
		1.Owner 4.Agent 7.
		2.Relative 5.Estimate 8.
		3.Tenant 6.Other 9.

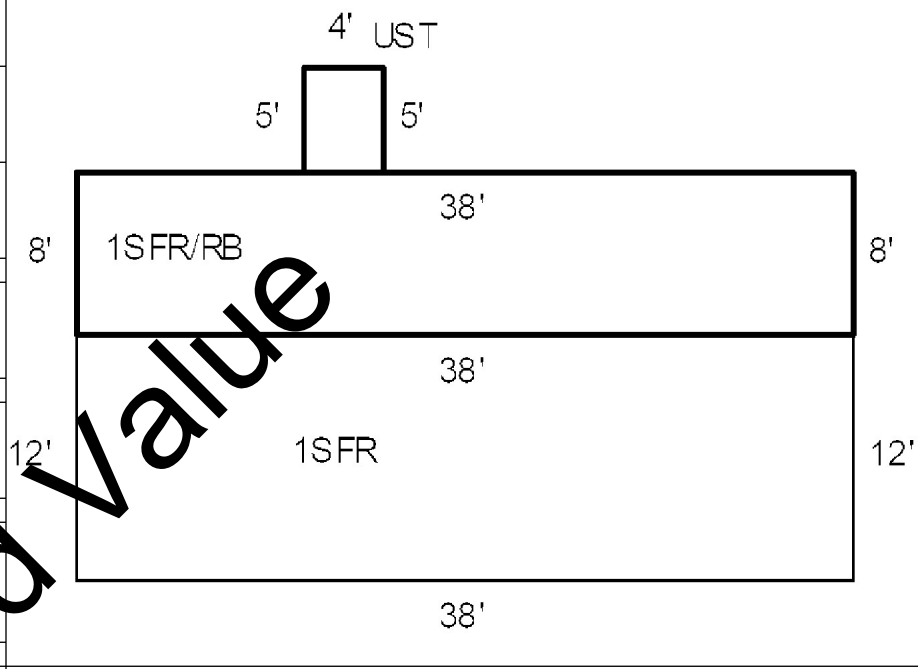

Date Inspected 5/08/2024

Additions, Outbuildings & Improvements

Type	Year	Units	Grade	Cond	Phys.	Funct.	Sound Value
1 One Story Frame	0	304	0 0	0	0 %	100 %	
19 Utility Storage	0	20	0 0	0	0 %	100 %	
27 Unfin Basement	0	304	0 0	0	0 %	100 %	
					%	%	
					%	%	
					%	%	
					%	%	
					%	%	
					%	%	
					%	%	
					%	%	

- 1.One Story Fram
- 2.Two Story Fram
- 3.Three Story Fr
- 4.1 & 1/2 Story
- 5.1 & 3/4 Story
- 6.2 & 1/2 Story
- 21.Open Frame Por
- 22.Encl Frame Por
- 23.Frame Garage
- 24.Frame Shed
- 25.Frame Bay Wind
- 26.1SFr Overhang
- 27.Unfin Basement
- 28.Unfinished Att
- 29.Finished Attic