

Gray

Map Lot 073-041-033-001

Account 2584

Location 4 CASWELL RD

Card 1

Of 1

8/05/2024

Building Style 10 Colonial	SF Bsmt Living 0	Layout 1 Typical
1.Conv. 5.Garrison 9.NE farm	Fin Bsmt Grade 0 0	1.Typical 4. 7.
2.Ranch 6.Split 10.Colonia	Secondary Heat 0	2.Inadeq 5. 8.
3.R Ranch/ 7.Contemp 11.Cottage	Heat Type 100% 1 Hot Water BB	3. 6. 9.
4.Cape 8.Log 12.Gambrel	1.HWBB 5.FWA 9.None	Attic 9 None
Dwelling Units 1	2.HWCI 6.Monitor 10.UNH2F	1.1/4 Fin 4.Full Fin 7.
Other Units 0	3.HWRF 7.Electric 11.Geother	2.1/2 Fin 5.F/Stair 8.
Stories 5 One & 3/4 Story	4.Steam 8.F/Wall 12.Heat/Co	3.3/4 Fin 6. 9.None
1.1 4.1.5 7.	Cool Type 0% 9 None	Insulation 1 Full
2.2 5.1.75 8.	1.Central 4.W&C Air 7.	1.Full 4.Minimal 7.
3.3 6.2.5 9.	2.Evapor 5. 8.	2.Heavy 5. 8.
Exterior Walls 2 Vinyl/Aluminum	3.H Pump 6. 9.None	3.Capped 6. 9.None
1.Clapboar 5.Stucco 9.B & B	Kitchen Style 2 Typical	Unfinished % 0%
2.Vin/Al 6.Brick 10.Cemplan	1.Modern 4.Obsolete	Grade & Factor 3 Average 120%
3.Compos./ 7.Stone 11.Concret	2.Typical 5. 8.	1.E Grade 4.B Grade 7.SC Grade
4.Asbestos 8.Wood Shi 12.Wood Bo	3.Old Type 6. 9.None	2.D Grade 5.A Grade 8.
Roof Surface 1 Asphalt Shingles	Bath(s) Style 2 Typical Bath(s)	3.Grade 6.AA Grade 9.Same
1.Asphalt 4.Composit 7.Other	1.Modern 4.Obsolete 7.	SQFT (Footprint) 896
2.Slate 5.Wood 8.	2.Typical 5. 8.	Condition 4 Average
3.Metal 6.Roll Roo 9.	3.Old Type 6. 9.None	1.Poor 2.Avg 7.V G
SF Masonry Trim 0	# Rooms 6	2.Fair 3.Good 8.Exc
SOLAR VOLTAIC 0	# Bedrooms 3	3.Avg- 4.Good 9.Same
OPEN-4- 0	# Full Baths 2	Phys. % Good 0%
Year Built 2006	# Half Baths 0	Funct. % Good 100%
Year Remodeled 0	# Addn Fixtures 0	Functional Code 9 None
Foundation 1 Concrete	# Fireplaces 0	1.Incomp 4.Delap 5.Layoff
1.Concrete 4.Wood 7.		2.O-Built 5.Bsmt 6.Long term
2.C Block 5.Slab 8.		3.Damage 6.Style None
3.Br/Stone 6.Piers 9.		Econ. % Good 100%
Basement 4 Full Basement		Economic Code None
1.1/4 Bmt 4.Full Bmt 7.		0.None 3.No Power 6.Obsoles
2.1/2 Bmt 5.Crw1 8.		1.Location 4.Generate 9.None
3.3/4 Bmt 6. 9.None		2.Encroach 5.Flood Pl 9.
Bsmt Gar # Cars 0		Entrance Code 5 Estimated
Wet Basement 1 Dry Basement		1.Interior 4.Vacant 7.
1.Dry 4. 7.		2.Refusal 5.Estimate 8.
2.Damp 5. 8.	3.Informed 6. 9.	
3.Wet 6. 9.	Information Code 5 Estimate	
	1.Owner 4.Agent 7.	
	2.Relative 5.Estimate 8.	
	3.Tenant 6.Other 9.	

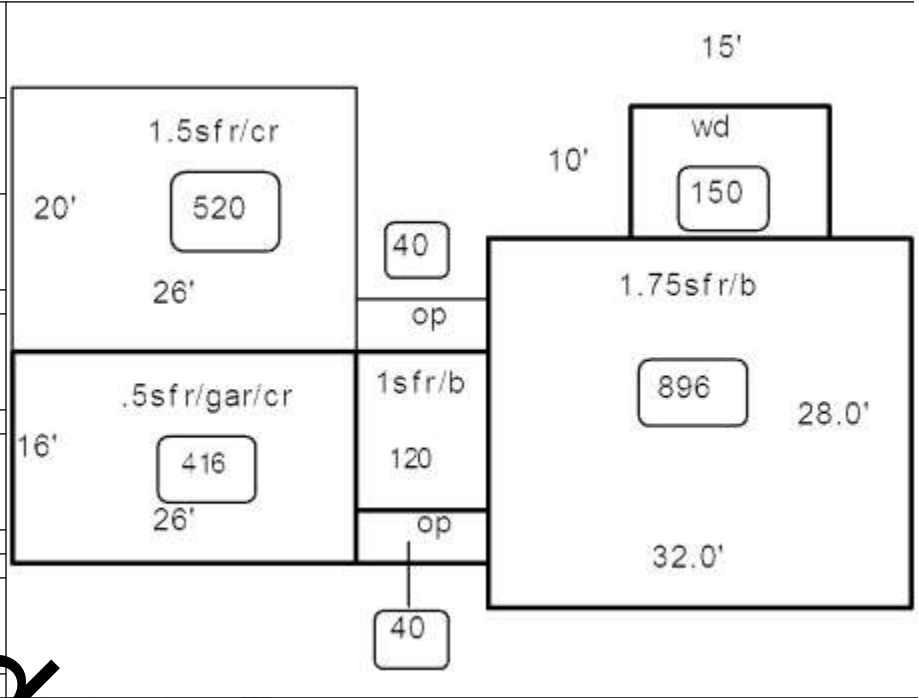

Date Inspected 5/30/2024

Additions, Outbuildings & Improvements

Type	Year	Units	Grade	Cond	Phys.	Funct.	Sound Value
14 1.5	0	120	0 0	0	0 %	100 %	
21 Open Frame	0	40	0 0	0	0 %	100 %	
74 1.5 St Garage	0	520	0 0	0	0 %	100 %	
21 Open Frame	0	40	0 0	0	0 %	100 %	
68 Wood Deck	0	150	0 0	0	0 %	100 %	
23 Frame Garage	0	416	0 0	0	0 %	100 %	
79 1/2 St/Garage	0	416	0 0	0	0 %	100 %	
					%	%	
					%	%	
					%	%	

- 1.One Story Fram
- 2.Two Story Fram
- 3.Three Story Fr
- 4.1 & 1/2 Story
- 5.1 & 3/4 Story
- 6.2 & 1/2 Story
- 21.Open Frame Por
- 22.Encl Frame Por
- 23.Frame Garage
- 24.Frame Shed
- 25.Frame Bay Wind
- 26.1SFr Overhang
- 27.Unfin Basement
- 28.Unfinished Att
- 29.Finished Attic