

MOORAD, JAMIL  
WOLF, CAITLIN  
4 PINE WOOD CIRCLE  
ARUNDEL ME 04046-8157

B37490P56

Previous Owner  
CARNICELLA, BETH A  
71 SUMMIT ROAD

GRAY ME 04039  
Sale Date: 11/25/2020

Property Data		
Neighborhood	82 Average Location	
Tree Growth Year	0	
REVIEW	0	
Building Permit	0	
Zone/Land Use	11 Rural Residential & Agri	
Secondary Zone		
Topography	2 Rolling	4 Below Street
1. Hill	4. Below St	7.
2. Rolling	5. Low	8.
3. Above St	6. Swampy	9.
Utilities	4 Filled Well/Point	6 Septic System
1. Public	4. Dug Well/Po	7. Cesspool
2. Water	5. Dug Well	8. Lake
3. Holding Ta	6. Septic	9. None
Street	3 Gravel	
1. Paved	4. Proposed	8.
2. Semi Imp	5. R/O/W	9.
3. Gravel	6.	9. None
GIS Map	58	
Field Review	1	
Sale Data		
Sale Date	11/25/2020	
Price	370,000	
Sale Type	2 Land & Buildings	
1. Land	4. Mobile	7. COM
2. L & B	5. Other	8.
3. Building	6. Condo	9.
Financing	1 Conventional	
1. Convent	4. Seller	7.
2. FHA/VA	5. Private	8.
3. Assumed	6. Cash	9. Unknown
Validity	1 Arms Length Sale	
1. Valid	4. Split	7. Multiple
2. Related	5. Partial	8. Other
3. Distress	6. Exempt	9. Estate
Verified	5 Public Record	
1. Buyer	4. Agent	7. Family
2. Seller	5. Pub Rec	8. Other
3. Lender	6. MLS	9.

Assessment Record				
Year	Land	Buildings	Exempt	Total
2011	48,980	116,503	0	165,483
2012	48,980	116,503	0	165,483
2013	48,980	116,503	0	165,483
2014	48,980	117,364	0	166,344
2015	49,000	117,400	0	166,400
2016	49,000	117,400	0	166,400
2017	49,000	117,400	13,500	152,900
2018	49,000	117,400	18,000	148,400
2019	61,400	182,400	20,000	223,800
2020	61,400	182,400	20,000	223,800
2021	61,400	182,400	25,000	218,800
2022	61,400	197,000	0	258,400
2023	61,400	220,900	0	282,300
Calc.	132,800	315,900	0	448,700

Land Data					
Type	Effective		Influence		Influence Codes
	Frontage	Depth	Factor	Code	
1. Water (0-200)			%		1. Unimproved
2. Water (201-400)			%		2. Excess Frtg
3. Water (401-800)			%		3. Topography
4. Water (801-1600)			%		4. Size/Shape
5. Water (1601-3200)			%		5. Access
6. Water (3201-6400)			%		6. Restriction
7. Water (6401-12800)			%		7. Open Space
8. Water (12801-25600)			%		8. Environmental
9. Water (25601-51200)			%		9. Condo
10. Water (51201-102400)			%		30. Blueberry(11-20
11. Water (102401-204800)			%		31. Blueberry(21 -
12. Water (204801-409600)			%		32. Crop Land
13. Water (409601-819200)			%		33. Pasture
14. Water (819201-1638400)			%		34. Shorefront B
15. Water (1638401-3276800)			%		35. Shorefront C
16. Water (3276801-6553600)			%		36. ANTENNA SITE
17. Water SF Amenities			%		37. Softwood TG
18. Water View			%		38. Mixed Wood TG
19. Water Influenced			%		39. Hardwood TG
20. ShoreFront A			%		40. Wasteland
21. Base Lot			%		41. Woodland
22. Base Lot Vacant			%		42. Mobile Home Si
23. Base Lot Unpaved			%		43. Camp Site
24. Acres to 10			%		44. Lot Improvemen
25. Acres 11-30			%		45. BA SF - Oce
26. Acres 31-50			%		46. SP Meadow Cond
27. Acres 51& over			%		
28. Acres 71 & Over			%		
29. Woods (41+)			%		
<b>Total Acreage</b>			3.98		

Inspection Witnessed By:

X	Date
No./Date	Description
	Date Insp.

Notes:  
5/24-FR=DR

Gray

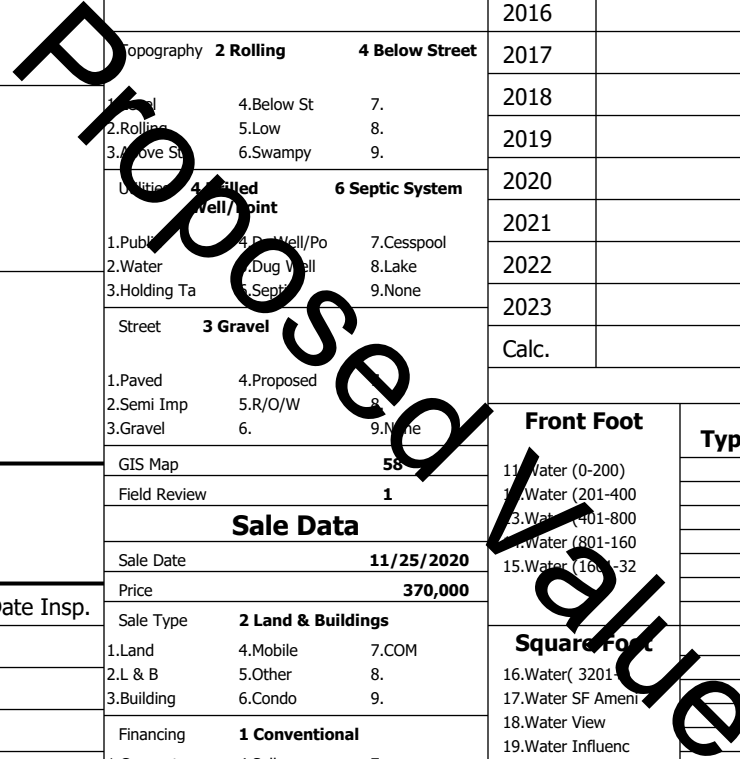

**Gray**

Map Lot 058-030-004-001

Account 1757

Location 71 SUMMIT RD

Card 1 Of 1

8/05/2024

Building Style <b>3 Raised Ranch/Split</b>	SF Bsmt Living <b>860</b>	Layout <b>1 Typical</b>
1.Conv. 5.Garrison 9.NE farm	Fin Bsmt Grade <b>4 100</b>	1.Typical 4. 7.
2.Ranch 6.Split 10.Colonia	Secondary Heat <b>2</b>	2.Inadeq 5. 8.
3.R Ranch/ 7.Contemp 11.Cottage	Heat Type <b>100% 1 Hot Water BB</b>	3. 6. 9.
4.Cape 8.Log 12.Gambrel	1.HWBB 5.FWA 9.None	Attic <b>9 None</b>
Dwelling Units <b>1</b>	2.HWCI 6.Monitor 10.UNH2F	1.1/4 Fin 4.Full Fin 7.
Other Units <b>0</b>	3.HWRF 7.Electric 11.Geother	2.1/2 Fin 5.FI/Stair 8.
Stories <b>1 One Story</b>	4.Steam 8.FI/Wall 12.Heat/Co	3.3/4 Fin 6. 9.None
1.1 4.1.5 7.	Cool Type <b>100% 4 Warm &amp; Cool Air</b>	Insulation <b>1 Full</b>
2.2 5.1.75 8.	1.Central 4.W&C Air 7.	1.Full 4.Minimal 7.
3.3 6.2.5 9.	2.Evapor 5. 8.	2.Heavy 5. 8.
Exterior Walls <b>16 Vertical Boards</b>	3.H Pump 6. 9.None	3.Capped 6. 9.None
1.Clapboard 5.Stucco 9.B & B	Kitchen Style <b>2 Typical</b>	Unfinished % <b>0%</b>
2.Vin/Al 6.Brick 10.Cemplan	1.Modern 4.Obsolete	Grade & Factor <b>3 Average 110%</b>
3.Compos./ 7.Stone 11.Concret	2.Typical 5. 8.	1.E Grade 4.B Grade 7.SC Grade
4.Asbestos 8.Wood Shi 12.Wood Bo	3.Old Type 6. 9.None	2.C Grade 5.A Grade 8.
Roof Surface <b>3 Metal</b>	Bath(s) Style <b>2 Typical Bath(s)</b>	3.C Grade 6.AA Grade 9.Same
1.Asphalt 4.Composit 7.Other	1.Modern 4.Obsolete 7.	SQFT (Footprint) <b>960</b>
2.Slate 5.Wood 8.	2.Typical 5. 8.	Condition <b>5 Good</b>
3.Metal 6.Roll Roo 9.	3.Old Type 6. 9.None	1.Poor Avg 7.V G
SF Masonry Trim <b>0</b>	# Rooms <b>5</b>	2.Fair Avg 8.Exc
SOLAR VOLTAIC <b>0</b>	# Bedrooms <b>3</b>	3.Avg- Good 9.Same
OPEN-4- <b>0</b>	# Full Baths <b>2</b>	Phys. % Good <b>0%</b>
Year Built <b>1990</b>	# Half Baths <b>0</b>	Funct. % Good <b>100%</b>
Year Remodeled <b>0</b>	# Addn Fixtures <b>2</b>	Functional Code <b>9 None</b>
Foundation <b>1 Concrete</b>	# Fireplaces <b>1</b>	1.Incomp 4.Delap 5.Layo
1.Concrete 4.Wood 7.		2.O-Built 5.Bsmt 6.Long term
2.C Block 5.Slab 8.		3.Damage 6.Style None
3.Br/Stone 6.Piers 9.		Econ. % Good <b>100%</b>
Basement <b>4 Full Basement</b>		Economic Code <b>None</b>
1.1/4 Bmt 4.Full Bmt 7.		0.None 3.No Power 6.Obsolete
2.1/2 Bmt 5.CrwI 8.		1.Location 4.Generate 9.None
3.3/4 Bmt 6. 9.None		2.Encroach 5.Flood Pl 9.
Bsmt Gar # Cars <b>0</b>		Entrance Code <b>5 Estimated</b>
Wet Basement <b>1 Dry Basement</b>		1.Interior 4.Vacant 7.
1.Dry 4. 7.		2.Refusal 5.Estimate 8.
2.Damp 5. 8.		3.Informed 6. 9.
3.Wet 6. 9.		Information Code <b>5 Estimate</b>
		1.Owner 4.Agent 7.
		2.Relative 5.Estimate 8.
		3.Tenant 6.Other 9.

Date Inspected 5/29/2024

**Additions, Outbuildings & Improvements**

Type	Year	Units	Grade	Cond	Phys.	Funct.	Sound Value
26 1Sfr Overhang	990	256	0 0	0	0	100 %	
68 Wood Deck	2015	40	0 0	0	0	100 %	
68 Wood Deck	990	256	0 0	0	0	100 %	
74 1.5 St Garage	2000	624	2 100	4	0	100 %	
93 Slab	2014	168	0 0	0	0	100 %	
24 Frame Shed	0	48	1 100	4	0	100 %	
62 Patio	0	160	0 0	0	0	100 %	
						%	
						%	
						%	

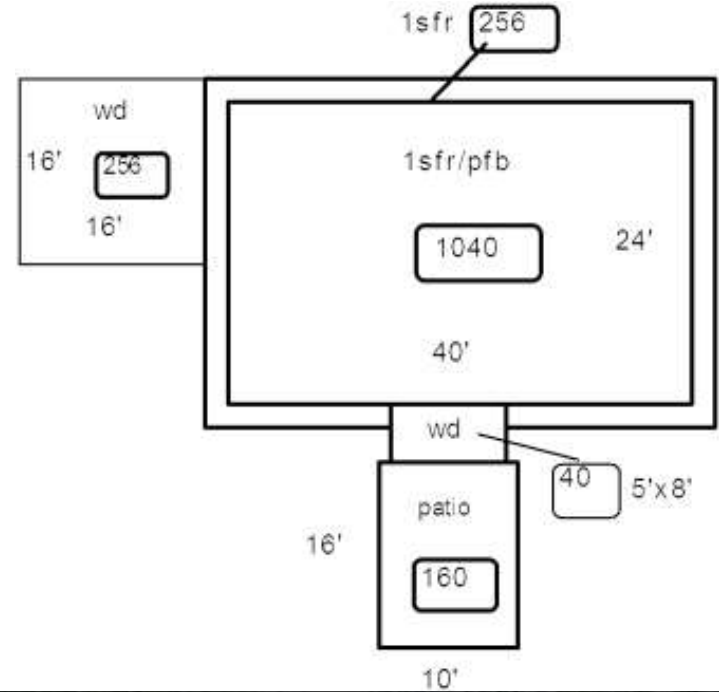

Proposed Value