



Gray

Map Lot 057-027-012-016

Account 1646

Location 46 FOX RUN RD

Card 1

Of 1

8/05/2024

Building Style <b>10 Colonial</b>	SF Bsmt Living <b>400</b>	Layout <b>1 Typical</b>
1.Conv. 5.Garrison 9.NE farm	Fin Bsmt Grade <b>3 100</b>	1.Typical 4. 7.
2.Ranch 6.Split 10.Colonia	Secondary Heat <b>8</b>	2.Inadeq 5. 8.
3.R Ranch/ 7.Contemp 11.Cottage	Heat Type <b>100% 1 Hot Water BB</b>	3. 6. 9.
4.Cape 8.Log 12.Gambrel	1.HWBB 5.FWA 9.None	Attic <b>9 None</b>
Dwelling Units <b>1</b>	2.HWCI 6.Monitor 10.UNH2F	1.1/4 Fin 4.Full Fin 7.
Other Units <b>0</b>	3.HWRF 7.Electric 11.Geother	2.1/2 Fin 5.F/Stair 8.
Stories <b>2 Two Story</b>	4.Steam 8.F/Wall 12.Heat/Co	3.3/4 Fin 6. 9.None
1.1 4.1.5 7.	Cool Type <b>100% 3 Heat Pump</b>	Insulation <b>1 Full</b>
2.2 5.1.75 8.	1.Central 4.W&C Air 7.	1.Full 4.Minimal 7.
3.3 6.2.5 9.	2.Evapor 5. 8.	2.Heavy 5. 8.
Exterior Walls <b>2 Vinyl/Aluminum</b>	3.H Pump 6. 9.None	3.Capped 6. 9.None
1.Clapboard 5.Stucco 9.B & B	Kitchen Style <b>2 Typical</b>	Unfinished % <b>0%</b>
2.Vin/Al 6.Brick 10.Cemplan	1.Modern 4.Obsolete	Grade & Factor <b>3 Average 120%</b>
3.Compos./ 7.Stone 11.Concret	2.Typical 5. 8.	1.E Grade 4.B Grade 7.SC Grade
4.Asbestos 8.Wood Shi 12.Wood Bo	3.Old Type 6. 9.None	2.C Grade 5.A Grade 8.
Roof Surface <b>1 Asphalt Shingles</b>	Bath(s) Style <b>2 Typical Bath(s)</b>	3.Grade 6.AA Grade 9.Same
1.Asphalt 4.Composit 7.Other	1.Modern 4.Obsolete 7.	SQFT (Footprint) <b>800</b>
2.Slate 5.Wood 8.	2.Typical 5. 8.	Condition <b>4 Average</b>
3.Metal 6.Roll Roo 9.	3.Old Type 6. 9.None	1.Poor Avg 7.V G
SF Masonry Trim <b>0</b>	# Rooms <b>6</b>	2.Fair Avg 8.Exc
SOLAR VOLTAIC <b>0</b>	# Bedrooms <b>3</b>	3.Avg-Good 9.Same
OPEN-4- <b>0</b>	# Full Baths <b>2</b>	Phys. % Good <b>0%</b>
Year Built <b>2006</b>	# Half Baths <b>1</b>	Funct. % Good <b>100%</b>
Year Remodeled <b>0</b>	# Addn Fixtures <b>0</b>	Functional Code <b>9 None</b>
Foundation <b>1 Concrete</b>	# Fireplaces <b>0</b>	1.Incomp 4.Delap 5.Layoff
1.Concrete 4.Wood 7.		2.O-Built 5.Bsmt 6.Long term
2.C Block 5.Slab 8.		3.Damage 6.Style None
3.Br/Stone 6.Piers 9.		Econ. % Good <b>100%</b>
Basement <b>4 Full Basement</b>		Economic Code <b>None</b>
1.1/4 Bmt 4.Full Bmt 7.		0.None 3.No Power 6.Obsolete
2.1/2 Bmt 5.Crwl 8.		1.Location 4.Generate 9.None
3.3/4 Bmt 6. 9.None		2.Encroach 5.Floor Pl 9.
Bsmt Gar # Cars <b>0</b>		Entrance Code <b>5 Estimated</b>
Wet Basement <b>1 Dry Basement</b>		1.Interior 4.Vacant 7.
1.Dry 4. 7.		2.Refusal 5.Estimate 8.
2.Damp 5. 8.	3.Informed 6. 9.	
3.Wet 6. 9.	Information Code <b>5 Estimate</b>	
	1.Owner 4.Agent 7.	
	2.Relative 5.Estimate 8.	
	3.Tenant 6.Other 9.	

Date Inspected 5/31/2024

Additions, Outbuildings & Improvements

Type	Year	Units	Grade	Cond	Phys.	Funct.	Sound Value
21 Open Frame	0	96	0 0	0	0	100 %	
68 Wood Deck	0	160	0 0	0	0	100 %	
74 1.5 St Garage	0	220	0 0	0	0	100 %	
26 1Sfr Overhang	0	32	0 0	0	0	100 %	
23 Frame Garage	0	264	0 0	0	0	100 %	
81 1 St/Garage	0	264	0 0	0	0	100 %	
24 Frame Shed	2011	120	3 100	4	0	100 %	
						%	
						%	
						%	

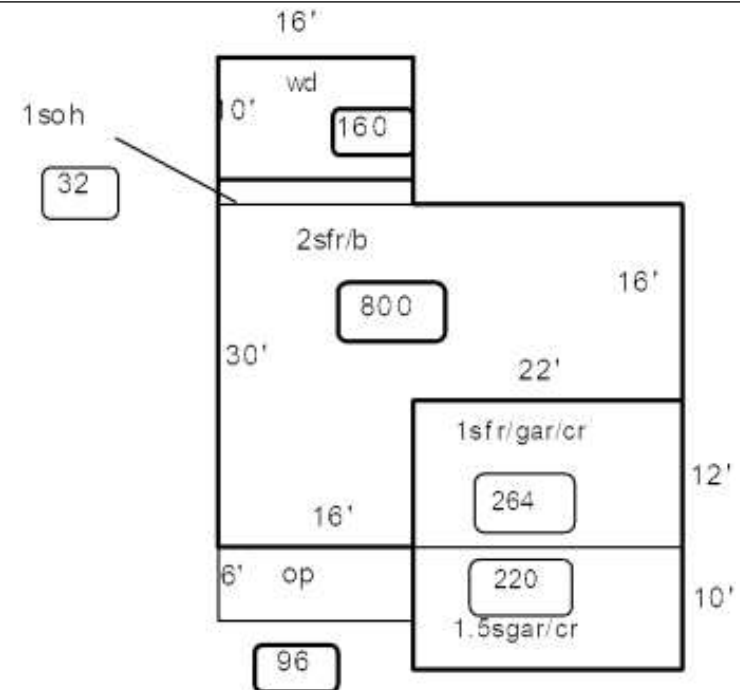

Proposed Value