



**Gray**

Map Lot 045-038-002-001

Account 2296

Location 164 YARMOUTH RD

Card 1

Of 1

8/05/2024

Building Style	SF Bsmt Living		Layout	
1.Conv.	5.Garrison	9.NE farm	1.Typical	4. 7.
2.Ranch	6.Split	10.Colonia	2.Inadeq	5. 8.
3.R Ranch/	7.Contemp	11.Cottage	3.	6. 9.
4.Cape	8.Log	12.Gambrel	Attic	
Dwelling Units	2.HWCI	6.Monitor	10.UNH2F	1.1/4 Fin 4.Full Fin 7.
Other Units	3.HWRF	7.Electric	11.Geother	2.1/2 Fin 5.FI/Stair 8.
Stories	4.Steam	8.FI/Wall	12.Heat/Co	3.3/4 Fin 6. 9.None
1.1	4.1.5	7.	Cool Type	Insulation
2.2	5.1.75	8.	1.Central	4.W&C Air 7.
3.3	6.2.5	9.	2.Evapor	5. 8.
Exterior Walls	3.H Pump	6. 9.None	2.H Pump	5. 8.
1.Clapboar	5.Stucco	9.B & B	3.Capped	6. 9.None
2.Vin/Al	6.Brick	10.Cemplan	Unfinished %	
3.Compos./	7.Stone	11.Concret	Grade & Factor	
4.Asbestos	8.Wood Shi	12.Wood Bo	1.E Grade	4.B Grade 7.SC Grade
Roof Surface	3.Old Type	6. 9.None	2.O Grade	5.A Grade 8.
1.Asphalt	4.Composit	7.Other	3.Old Type	6.AA Grade 9.Same
2.Slate	5.Wood	8.	Bath(s) Style	
3.Metal	6.Roll Roo	9.	1.Modern	4.Obsolete 7.
SF Masonry Trim	# Rooms		2.Typical	5. 8.
SOLAR VOLTAIC	# Bedrooms		3.Old Type	6. 9.None
OPEN-4-	# Full Baths		3.Old Type	6. 9.None
Year Built	# Half Baths		Fireplaces	
Year Remodeled	# Addn Fixtures		1.Poor	2.Avg 7.V G
Foundation	# Fireplaces		2.Fair	3.Avg 8.Exc
1.Concrete	4.Wood	7.	3.Avg-	9.Good 9.Same
2.C Block	5.Slab	8.	Phys. % Good	
3.Br/Stone	6.Piers	9.	Funct. % Good	
Basement			Functional Code	
1.1/4 Bmt	4.Full Bmt	7.	1.Incomp	4.Delap 5.Layoff
2.1/2 Bmt	5.Crwl	8.	2.O-Built	5.Bsmt 6.Long term
3.3/4 Bmt	6. 9.None		3.Damage	6.Style 7.None
Bsmt Gar # Cars			Econ. % Good	
Wet Basement			Economic Code	
1.Dry	4. 7.		0.None	3.No Power 6.Obsolete
2.Damp	5. 8.		1.Location	4.Generate 9.None
3.Wet	6. 9.		2.Encroach	5.Flood Pl 9.



Date Inspected 5/17/2024

**Additions, Outbuildings & Improvements**

Type	Year	Units	Grade	Cond	Phys.	Funct.	Sound Value
998 14Mobile Home	1979	14x64	3 100	6	0	% 100 %	
27 Unfin Basement	1979	924	2 100	0	0	% 100 %	
23 Frame Garage	1995	576	3 100	4	0	% 100 %	
24 Frame Shed	0	160	2 100	4	0	% 100 %	
68 Wood Deck	2010	180	0 0	0	0	% 100 %	
1 One Story Frame	0	340	0 0	0	0	% 100 %	
21 Open Frame	0	300	0 0	0	0	% 100 %	
						% %	
						% %	
						% %	

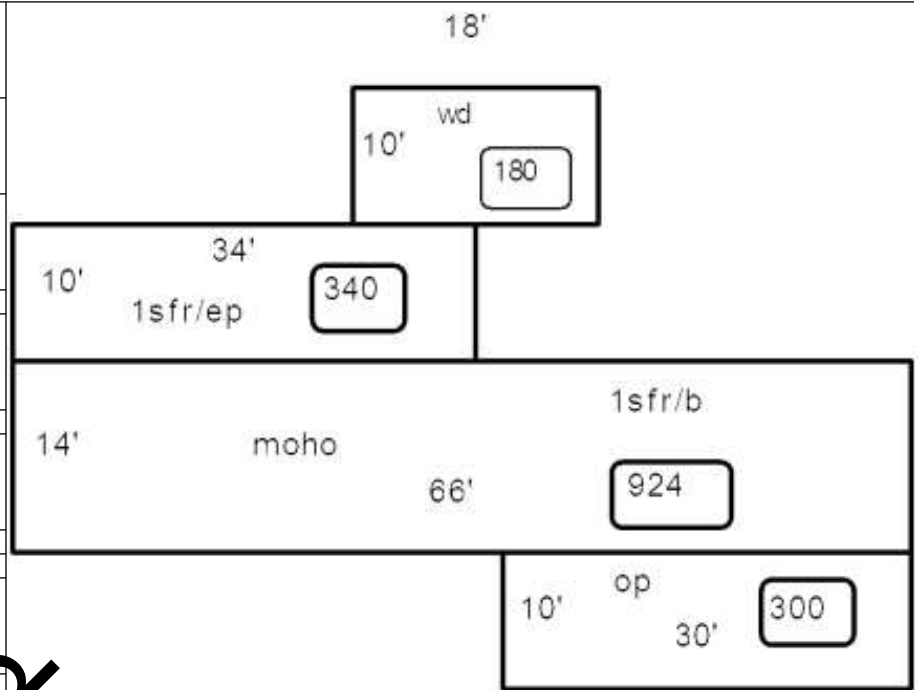

Proposed Value