

TOZIER, TOBEY RAYMOND  
SMITH, MALLORY CARINA  
41 MERRILL ROAD  
GRAY ME 04039-9553

B28583P196

Previous Owner  
DANA, KIMBERLY JEAN  
212 CONGRESS AVE

BATH ME 04530  
Sale Date: 7/17/2020

Property Data		
Neighborhood	82 Average Location	
Tree Growth Year	0	
REVIEW	0	
Building Permit	0	
Zone/Land Use	11 Rural Residential & Agri	
Secondary Zone	25 Stream Protection	
Topography	2 Rolling	
1. Soil	4. Below St	7.
2. Rolling	5. Low	8.
3. Above St	6. Swampy	9.
Utilities	2 Public Water 6 Septic System	
1. Public	4. Dr. Well/Po	7. Cesspool
2. Water	5. Dug Well	8. Lake
3. Holding Ta	6. Septic	9. None
Street	1 Paved	
1. Paved	4. Proposed	8.
2. Semi Imp	5. R/O/W	9.
3. Gravel	6.	
GIS Map	37	
Field Review	1	
Sale Data		
Sale Date	7/17/2020	
Price	64,100	
Sale Type	1 Land Only	
1. Land	4. Mobile	7. COM
2. L & B	5. Other	8.
3. Building	6. Condo	9.
Financing	1 Conventional	
1. Convent	4. Seller	7.
2. FHA/VA	5. Private	8.
3. Assumed	6. Cash	9. Unknown
Validity	1 Arms Length Sale	
1. Valid	4. Split	7. Multiple
2. Related	5. Partial	8. Other
3. Distress	6. Exempt	9. Estate
Verified	5 Public Record	
1. Buyer	4. Agent	7. Family
2. Seller	5. Pub Rec	8. Other
3. Lender	6. MLS	9.

Assessment Record				
Year	Land	Buildings	Exempt	Total
2011	35,730	0	0	35,730
2012	35,910	0	0	35,910
2013	35,910	0	0	35,910
2014	35,910	0	0	35,910
2015	35,900	0	0	35,900
2016	35,900	0	0	35,900
2017	35,900	0	0	35,900
2018	35,900	0	0	35,900
2019	43,400	0	0	43,400
2020	43,400	2,100	0	45,500
2021	43,400	2,100	0	45,500
2022	65,900	96,200	0	162,100
2023	65,900	129,700	0	195,600
Calc.	131,400	60,300	0	191,700

Land Data						
Front Foot	Type	Effective		Influence		Influence Codes
		Frontage	Depth	Factor	Code	
11. Water (0-200)				%		1. Unimproved
12. Water (201-400)				%		2. Excess Frtg
13. Water (401-800)				%		3. Topography
14. Water (801-1600)				%		4. Size/Shape
15. Water (1601-3200)				%		5. Access
				%		6. Restriction
				%		7. Open Space
				%		8. Environmental
				%		9. Condo
Square Foot	Square Feet				Acres	
16. Water (3201-6400)				%		30. Blueberry(1-20
17. Water SF Amen				%		31. Blueberry(21 -
18. Water View				%		32. Crop Land
19. Water Influen				%		33. Pasture
20. ShoreFront A				%		34. Shorefront B
				%		35. Shorefront C
				%		36. ANTENNA SITE
21. Base Lot	21	1.84	100	%	0	37. Softwood TG
22. Base Lot Vacan	24	1.07	100	%	0	38. Mixed Wood TG
23. Base Lot Unpav				%		39. Hardwood TG
				%		40. Wasteland
				%		41. Woodland
				%		42. Mobile Home Si
				%		43. Camp Site
				%		44. Lot Improvemen
				%		45. BA SF - Oce
				%		46. SP Meadow Cond
<b>Fract. Acre</b>		<b>Acres/Sites</b>				
24. Acres to 10						
25. Acres 11-30						
26. Acres 31-50						
27. Acres 51& over						
28. Acres 71 & Ove						
29. Woods (41+)						
		<b>Total Acreage</b>	2.91			

Inspection Witnessed By:

X	Date	Date Insp.
No./Date	Description	Date Insp.

Notes:  
5/24-FR=DR

Gray

**Gray**

Map Lot 037-039-001-004

Account 2377

Location 41 MERRILL RD

Card 1

Of 1

8/05/2024

Building Style <b>29 Tiny Home</b>	SF Bsmt Living <b>0</b>	Layout <b>1 Typical</b>
1.Conv. 5.Garrison 9.NE farm	Fin Bsmt Grade <b>0 0</b>	1.Typical 4. 7.
2.Ranch 6.Split 10.Colonia	Secondary Heat <b>0</b>	2.Inadeq 5. 8.
3.R Ranch/ 7.Contemp 11.Cottage	Heat Type <b>100% 13 W Stove</b>	3. 6. 9.
4.Cape 8.Log 12.Gambrel	1.HWBB 5.FWA 9.None	Attic <b>9 None</b>
Dwelling Units <b>1</b>	2.HWCI 6.Monitor 10.UNH2F	1.1/4 Fin 4.Full Fin 7.
Other Units <b>0</b>	3.HWRF 7.Electric 11.Geother	2.1/2 Fin 5.FI/Stair 8.
Stories <b>4 One &amp; 1/2 Story</b>	4.Steam 8.FI/Wall 12.Heat/Co	3.3/4 Fin 6. 9.None
1.1 4.1.5 7.	Cool Type <b>0% 9 None</b>	Insulation <b>1 Full</b>
2.2 5.1.75 8.	1.Central 4.W&C Air 7.	1.Full 4.Minimal 7.
3.3 6.2.5 9.	2.Evapor 5. 8.	2.Heavy 5. 8.
Exterior Walls <b>8 Wood Shingle</b>	3.H Pump 6. 9.None	3.Capped 6. 9.None
1.Clapboar 5.Stucco 9.B & B	Kitchen Style <b>2 Typical</b>	Unfinished % <b>0%</b>
2.Vin/Al 6.Brick 10.Cemplan	1.Modern 4.Obsolete	Grade & Factor <b>3 Average 100%</b>
3.Compos./ 7.Stone 11.Concret	2.Typical 5. 8.	1.E Grade 4.B Grade 7.SC Grade
4.Asbestos 8.Wood Shi 12.Wood Bo	3.Old Type 6. 9.None	2.D Grade 5.A Grade 8.
Roof Surface <b>1 Asphalt Shingles</b>	Bath(s) Style <b>2 Typical Bath(s)</b>	3.Grade 6.AA Grade 9.Same
1.Asphalt 4.Composit 7.Other	1.Modern 4.Obsolete 7.	SQFT (Footprint) <b>198</b>
2.Slate 5.Wood 8.	2.Typical 5. 8.	Foundation <b>4 Average</b>
3.Metal 6.Roll Roo 9.	3.Old Type 6. 9.None	1.Poor 4.Avg 7.V G
SF Masonry Trim <b>0</b>	# Rooms <b>3</b>	2.Fair 5.Avg 8.Exc
SOLAR VOLTAIC <b>0</b>	# Bedrooms <b>1</b>	3.Avg- 6.Good 9.Same
OPEN-4- <b>0</b>	# Full Baths <b>1</b>	Phys. % Good <b>0%</b>
Year Built <b>2023</b>	# Half Baths <b>0</b>	Funct. % Good <b>0%</b>
Year Remodeled <b>0</b>	# Addn Fixtures <b>0</b>	Functional Code <b>6 Style</b>
Foundation <b>6 Piers</b>	# Fireplaces <b>0</b>	1.Incomp 4.Delap 9.Layoff
1.Concrete 4.Wood 7.		2.O-Built 5.Bsmt 8.Long term
2.C Block 5.Slab 8.		3.Damage 6.Style 9.None
3.Br/Stone 6.Piers 9.		Econ. % Good <b>100%</b>
Basement <b>9 No Basement</b>		Economic Code <b>None</b>
1.1/4 Bmt 4.Full Bmt 7.		0.None 3.No Power 6.Obsolete
2.1/2 Bmt 5.CrwI 8.		1.Location 4.Generate 9.None
3.3/4 Bmt 6. 9.None		2.Encroach 5.Flood Pl 9.
Bsmt Gar # Cars <b>0</b>		Entrance Code <b>5 Estimated</b>
Wet Basement <b>0</b>		1.Interior 4.Vacant 7.
1.Dry 4. 7.		2.Refusal 5.Estimate 8.
2.Damp 5. 8.		3.Informed 6. 9.
3.Wet 6. 9.		Information Code <b>5 Estimate</b>
		1.Owner 4.Agent 7.
		2.Relative 5.Estimate 8.
		3.Tenant 6.Other 9.



Date Inspected 5/23/2024

**Additions, Outbuildings & Improvements**

Type	Year	Units	Grade	Cond	Phys.	Funct.	Sound Value
24 Frame Shed	2017	200	3 110	4	0 %	100 %	
68 Wood Deck	2023	264	1 100	2	0 %	100 %	
62 Patio	2023	81	3 100	4	0 %	100 %	
					%	%	
					%	%	
					%	%	
					%	%	
					%	%	
					%	%	
					%	%	
					%	%	

**Tiny Home**

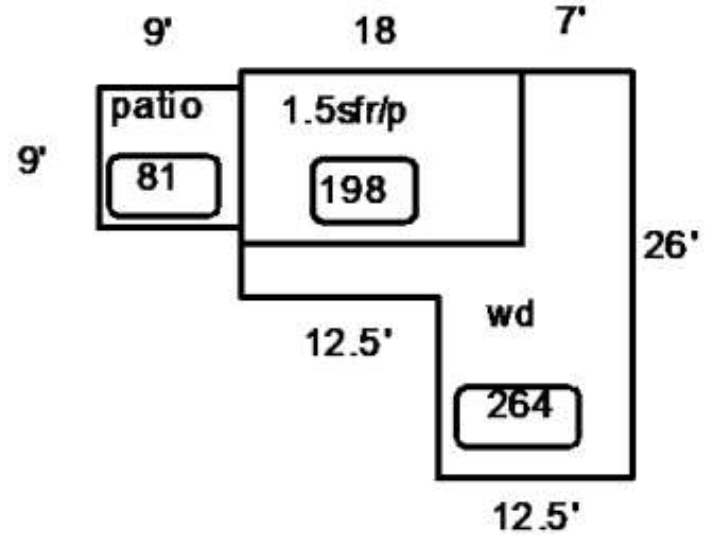

Proposed Value