



**Gray**

Map Lot 027-025-019-000

Account 1380

Location 51 LEWISTON RD

Card 1

Of 1

8/05/2024

Building Style <b>4 Cape Cod</b>	SF Bsmt Living <b>0</b>	Layout <b>1 Typical</b>
1.Conv. 5.Garrison 9.NE farm	Fin Bsmt Grade <b>0 0</b>	1.Typical 4. 7.
2.Ranch 6.Split 10.Colonia	Secondary Heat <b>0</b>	2.Inadeq 5. 8.
3.R Ranch/ 7.Contemp 11.Cottage	Heat Type <b>100% 1 Hot Water BB</b>	3. 6. 9.
4.Cape 8.Log 12.Gambrel	1.HWBB 5.FWA 9.None	Attic <b>9 None</b>
Dwelling Units <b>1</b>	2.HWCI 6.Monitor 10.UNH2F	1.1/4 Fin 4.Full Fin 7.
Other Units <b>0</b>	3.HWRF 7.Electric 11.Geother	2.1/2 Fin 5.FI/Stair 8.
Stories <b>4 One &amp; 1/2 Story</b>	4.Steam 8.FI/Wall 12.Heat/Co	3.3/4 Fin 6. 9.None
1.1 4.1.5 7.	Cool Type <b>0% 9 None</b>	Insulation <b>1 Full</b>
2.2 5.1.75 8.	1.Central 4.W&C Air 7.	1.Full 4.Minimal 7.
3.3 6.2.5 9.	2.Evapor 5. 8.	2.Heavy 5. 8.
Exterior Walls <b>2 Vinyl/Aluminum</b>	3.H Pump 6. 9.None	3.Capped 6. 9.None
1.Clapboar 5.Stucco 9.B & B	Kitchen Style <b>2 Typical</b>	Unfinished % <b>0%</b>
2.Vin/Al 6.Brick 10.Cemplan	1.Modern 4.Obsolete	Grade & Factor <b>3 Average 110%</b>
3.Compos./ 7.Stone 11.Concret	2.Typical 5. 8.	1.E Grade 4.B Grade 7.SC Grade
4.Asbestos 8.Wood Shi 12.Wood Bo	3.Old Type 6. 9.None	2.D Grade 5.A Grade 8.
Roof Surface <b>1 Asphalt Shingles</b>	Bath(s) Style <b>2 Typical Bath(s)</b>	3.Grade 6.AA Grade 9.Same
1.Asphalt 4.Composit 7.Other	1.Modern 4.Obsolete 7.	SQFT (Footprint) <b>910</b>
2.Slate 5.Wood 8.	2.Typical 5. 8.	Foundation <b>4 Average</b>
3.Metal 6.Roll Roo 9.	3.Old Type 6. 9.None	1.Poor 4.Avg 7.V G
SF Masonry Trim <b>0</b>	# Rooms <b>5</b>	2.Fair 5.Avg 8.Exc
SOLAR VOLTAIC <b>0</b>	# Bedrooms <b>3</b>	3.Avg- 6.Good 9.Same
OPEN-4- <b>0</b>	# Full Baths <b>1</b>	Phys. % Good <b>0%</b>
Year Built <b>1948</b>	# Half Baths <b>0</b>	Funct. % Good <b>100%</b>
Year Remodeled <b>0</b>	# Addn Fixtures <b>0</b>	Functional Code <b>9 None</b>
Foundation <b>2 Concrete Block</b>	# Fireplaces <b>0</b>	1.Incomp 4.Delap 8.Layoff
1.Concrete 4.Wood 7.		2.O-Built 5.Bsmt 8.Long term
2.C Block 5.Slab 8.		3.Damage 6.Style 9.None
3.Br/Stone 6.Piers 9.		Econ. % Good <b>100%</b>
Basement <b>4 Full Basement</b>		Economic Code <b>None</b>
1.1/4 Bmt 4.Full Bmt 7.		0.None 3.No Power 6.Obsolete
2.1/2 Bmt 5.Crw 8.		1.Location 4.Generate 9.None
3.3/4 Bmt 6. 9.None		2.Encroach 5.Flood Pl 9.
Bsmt Gar # Cars <b>0</b>		Entrance Code <b>5 Estimated</b>
Wet Basement <b>1 Dry Basement</b>		1.Interior 4.Vacant 7.
1.Dry 4. 7.		2.Refusal 5.Estimate 8.
2.Damp 5. 8.	3.Informed 6. 9.	
3.Wet 6. 9.	Information Code <b>5 Estimate</b>	
	1.Owner 4.Agent 7.	
	2.Relative 5.Estimate 8.	
	3.Tenant 6.Other 9.	

Date Inspected 5/15/2024

**Additions, Outbuildings & Improvements**

Type	Year	Units	Grade	Cond	Phys.	Funct.	Sound Value
1 One Story Frame	1976	352	3 100	5	0 %	100 %	1.One Story Fram
68 Wood Deck	0	176	0 0	0	0 %	100 %	2.Two Story Fram
22 Encl Frame Porch	0	60	0 0	0	0 %	100 %	3.Three Story Fr
23 Frame Garage	0	500	0 0	0	0 %	100 %	4.1 & 1/2 Story
					%	%	5.1 & 3/4 Story
					%	%	6.2 & 1/2 Story
					%	%	21.Open Frame Por
					%	%	22.Encl Frame Por
					%	%	23.Frame Garage
					%	%	24.Frame Shed
					%	%	25.Frame Bay Wind
					%	%	26.1SFr Overhang
					%	%	27.Unfin Basement
					%	%	28.Unfinished Att
					%	%	29.Finished Attic

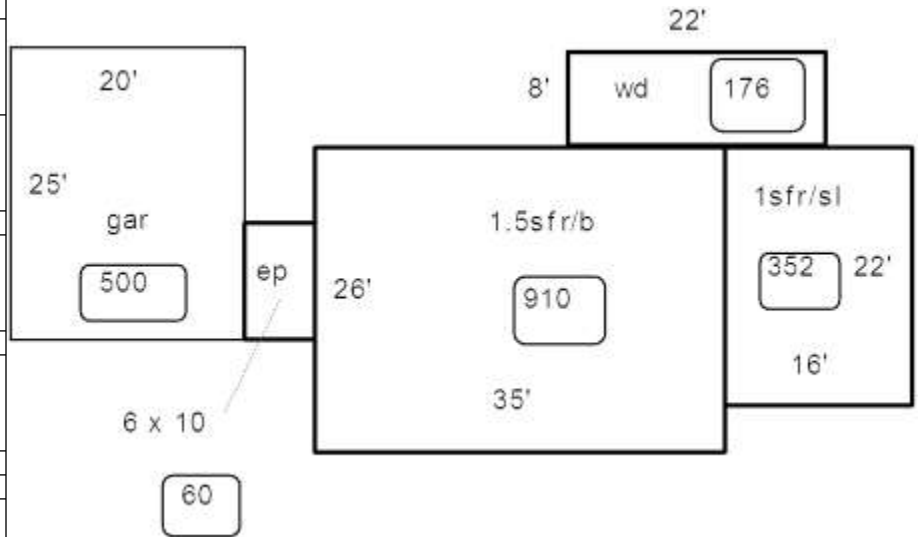

Proposed Value