

KENT, KALEB C  
36 REVOLUTION DRIVE  
WINDHAM ME 04062

B39423P74

Previous Owner  
HUTTON, AMY D  
HUTTON, PAUL S  
385 MAYALL ROAD  
GRAY ME 04039  
Sale Date: 5/13/2022

Previous Owner  
HODGES, AMY D  
HUTTON, PAUL S  
385 MAYALL RD.  
GRAY ME 04039  
Sale Date: 2/03/2020

Previous Owner  
BROOKS, STEPHANIE  
385 MAYALL RD

GRAY ME 04039  
Sale Date: 11/30/2017

Inspection Witnessed By:

X	Date	Date Insp.
No./Date	Description	Date Insp.

Notes:  
5/24- DR FIELD REVIEW

Gray

Property Data		
Neighborhood	82 Average Location	
Tree Growth Year	0	
REVIEW	0	
Building Permit	0	
Zone/Land Use	11 Rural Residential & Agri	
Secondary Zone		
Topography	1 Level	
1. Well	4. Below St	7.
2. Rolling	5. Low	8.
3. Above St	6. Swampy	9.
Utilities	4. Filled Well/Point	7 Cesspool
1. Public	4. Dug Well/Po	7. Cesspool
2. Water	5. Dug Well	8. Lake
3. Holding Ta	6. Septic	9. None
Street	1 Paved	
1. Paved	4. Proposed	8.
2. Semi Imp	5. R/O/W	9.
3. Gravel	6.	9. None
GIS Map	10	
Field Review	1	
Sale Data		
Sale Date	5/13/2022	
Price	375,000	
Sale Type	2 Land & Buildings	
1. Land	4. Mobile	7. COM
2. L & B	5. Other	8.
3. Building	6. Condo	9.
Financing	1 Conventional	
1. Convent	4. Seller	7.
2. FHA/VA	5. Private	8.
3. Assumed	6. Cash	9. Unknown
Validity	1 Arms Length Sale	
1. Valid	4. Split	7. Multiple
2. Related	5. Partial	8. Other
3. Distress	6. Exempt	9. Estate
Verified	5 Public Record	
1. Buyer	4. Agent	7. Family
2. Seller	5. Pub Rec	8. Other
3. Lender	6. MLS	9.

Assessment Record				
Year	Land	Buildings	Exempt	Total
2011	48,200	109,579	0	157,779
2012	48,200	109,579	0	157,779
2013	48,200	121,530	0	169,730
2014	48,200	130,364	0	178,564
2015	48,200	130,400	9,000	169,600
2016	48,200	130,400	9,000	169,600
2017	48,200	130,400	13,500	165,100
2018	48,200	130,400	18,000	160,600
2019	66,700	166,700	0	233,400
2020	66,700	166,700	0	233,400
2021	66,700	166,700	0	233,400
2022	66,700	166,700	0	233,400
2023	66,700	193,900	0	260,600
Calc.	133,200	250,800	0	384,000

Land Data					
Type	Effective		Influence		Influence Codes
	Frontage	Depth	Factor	Code	
11. Water (0-200)			%		1. Unimproved
12. Water (201-400)			%		2. Excess Frtg
13. Water (401-800)			%		3. Topography
14. Water (801-160)			%		4. Size/Shape
15. Water (1601-32)			%		5. Access
			%		6. Restriction
			%		7. Open Space
			%		8. Environmental
			%		9. Condo
Square Foot		Square Feet		Acres	
16. Water ( 3201-			%		30. Blueberry(1-20
17. Water SF Amen			%		31. Blueberry(21 -
18. Water View			%		32. Crop Land
19. Water Influen			%		33. Pasture
20. ShoreFront A			%		34. Shorefront B
			%		35. Shorefront C
			%		36. ANTENNA SITE
21. Base Lot	1.84	100	%	0	37. Softwood TG
22. Base Lot Vacan	1.36	100	%	0	38. Mixed Wood TG
23. Base Lot Unpav			%		39. Hardwood TG
			%		40. Wasteland
			%		41. Woodland
			%		42. Mobile Home Si
			%		43. Camp Site
			%		44. Lot Improvemen
			%		45. BA SF - Oce
			%		46. SP Meadow Cond
<b>Total Acreage</b>		3.20			

**Gray**

Map Lot 010-021-007-002

Account 1135

Location 385 MAYALL RD

Card 1

Of 1

8/05/2024

Building Style <b>4 Cape Cod</b>	SF Bsmt Living <b>0</b>	Layout <b>1 Typical</b>
1.Conv. 5.Garrison 9.NE farm	Fin Bsmt Grade <b>0 0</b>	1.Typical 4. 7.
2.Ranch 6.Split 10.Colonia	Secondary Heat <b>0</b>	2.Inadeq 5. 8.
3.R Ranch/ 7.Contemp 11.Cottage	Heat Type <b>100% 1 Hot Water BB</b>	3. 6. 9.
4.Cape 8.Log 12.Gambrel	1.HWB 5.FWA 9.None	Attic <b>9 None</b>
Dwelling Units <b>1</b>	2.HWCI 6.Monitor 10.UNH2F	1.1/4 Fin 4.Full Fin 7.
Other Units <b>0</b>	3.HWRF 7.Electric 11.Geother	2.1/2 Fin 5.FI/Stair 8.
Stories <b>5 One &amp; 3/4 Story</b>	4.Steam 8.FI/Wall 12.Heat/Co	3.3/4 Fin 6. 9.None
1.1 4.1.5 7.	Cool Type <b>0% 9 None</b>	Insulation <b>1 Full</b>
2.2 5.1.75 8.	1.Central 4.W&C Air 7.	1.Full 4.Minimal 7.
3.3 6.2.5 9.	2.Evapor 5. 8.	2.Heavy 5. 8.
Exterior Walls <b>2 Vinyl/Aluminum</b>	3.H Pump 6. 9.None	3.Capped 6. 9.None
1.Clapboard 5.Stucco 9.B & B	Kitchen Style <b>2 Typical</b>	Unfinished % <b>0%</b>
2.Vin/Al 6.Brick 10.Cemplan	1.Modern 4.Obsolete	Grade & Factor <b>3 Average 100%</b>
3.Compos./ 7.Stone 11.Concret	2.Typical 5. 8.	1.E Grade 4.B Grade 7.SC Grade
4.Asbestos 8.Wood Shi 12.Wood Bo	3.Old Type 6. 9.None	2.C Grade 5.A Grade 8.
Roof Surface <b>1 Asphalt Shingles</b>	Bath(s) Style <b>2 Typical Bath(s)</b>	3.Grade 6.AA Grade 9.Same
1.Asphalt 4.Composit 7.Other	1.Modern 4.Obsolete 7.	SQFT (Footprint) <b>600</b>
2.Slate 5.Wood 8.	2.Typical 5. 8.	Condition <b>4 Average</b>
3.Metal 6.Roll Roo 9.	3.Old Type 6. 9.None	1.Poor 2.Avg 7.V G
SF Masonry Trim <b>0</b>	# Rooms <b>6</b>	2.Fair 3.Good 8.Exc
SOLAR VOLTAIC <b>0</b>	# Bedrooms <b>3</b>	3.Avg- 4.Good 9.Same
OPEN-4- <b>0</b>	# Full Baths <b>1</b>	Phys. % Good <b>0%</b>
Year Built <b>1983</b>	# Half Baths <b>1</b>	Funct. % Good <b>100%</b>
Year Remodeled <b>0</b>	# Addn Fixtures <b>0</b>	Functional Code <b>9 None</b>
Foundation <b>1 Concrete</b>	# Fireplaces <b>0</b>	1.Incomp 4.Delay 5.Layoff
1.Concrete 4.Wood 7.		2.O-Built 5.Bsmt 6.Long term
2.C Block 5.Slab 8.		3.Damage 6.Style 7.None
3.Br/Stone 6.Piers 9.		Econ. % Good <b>100%</b>
Basement <b>4 Full Basement</b>		Economic Code <b>None</b>
1.1/4 Bmt 4.Full Bmt 7.		0.None 3.No Power 6.Obsolete
2.1/2 Bmt 5.Crwl 8.		1.Location 4.Generate 9.None
3.3/4 Bmt 6. 9.None		2.Encroach 5.Flood Pl 9.
Bsmt Gar # Cars <b>0</b>		Entrance Code <b>5 Estimated</b>
Wet Basement <b>1 Dry Basement</b>		1.Interior 4.Vacant 7.
1.Dry 4. 7.		2.Refusal 5.Estimate 8.
2.Damp 5. 8.		3.Informed 6. 9.
3.Wet 6. 9.		Information Code <b>5 Estimate</b>
		1.Owner 4.Agent 7.
		2.Relative 5.Estimate 8.
		3.Tenant 6.Other 9.

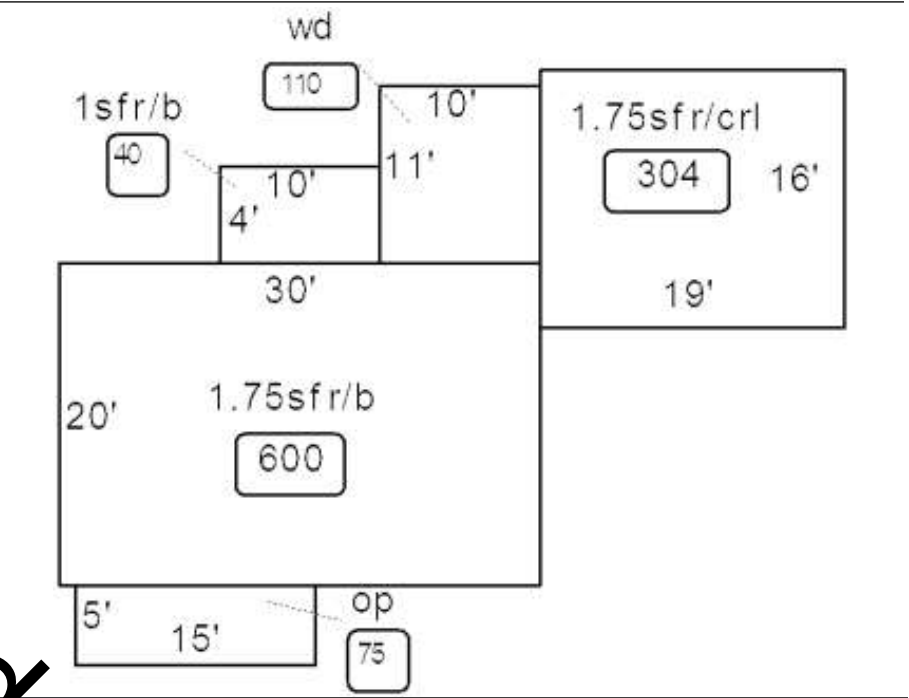

Date Inspected 5/16/2024

Additions, Outbuildings & Improvements							
Type	Year	Units	Grade	Cond	Phys.	Funct.	Sound Value
5 1 & 3/4 Story Fr	2011	304	0 0	0	0	100 %	
68 Wood Deck	2010	110	0 0	0	0	100 %	
11 1 Story/Basement	1983	40	0 0	0	0	100 %	
21 Open Frame	1983	75	0 0	0	0	100 %	
55 1st Barn	1983	1280	2 100	3	0	100 %	
						%	%
						%	%
						%	%
						%	%
						%	%
						%	%



Value